

Version:TR8B(11/2023)

Weekly programmable handwheel thermostat with color LCD screen

- ✓ Diverse programming options that fit any lifestyle - up to 6 heating events with individual temperature settings.
- ✓ Color VA screen (vertical alignment technology)- wide view, high brightness, and high contrast.
- ✓ Intelligent weather display - support multiple weather display, can view weather information at any time. (Wi-Fi version only)
- ✓ Set temperature can be specified precisely and intuitive via handwheel (by 0.5°C).
- ✓ Capacitive touch button - provide a friendly interactive way.

Parameter

Supply voltage	AC100~240V; 50/60Hz
Power consumption	1W Max (Wi-Fi version 1.5W Max)
Temperature setting range	5~95°C
External sensor upper limit	5~60°C
Switch deviation	0.5~10°C, Factory setting 1°C
Ambient temperature	-5~50°C
Protection level	IP20
housing material	Anti-Flammable PC

Product Overview

This series of thermostats are designed to meet the different scenarios of floor heating application. Wi-Fi version supports remote control including smart phone control and voice control. Thanks to built-in temperature sensors and weekly programming setting, the desired temperature can be comfortably adjusted. With the device you can conveniently regulate the room temperature.

Function	Model	Application
Floor heating	EP	External sensor + Weekly programming + 16A max
	WP	External sensor(optional) + Weekly programming + 3A max
	WPB	Passive linkage control + Weekly programming + 3A max

Display Symbols

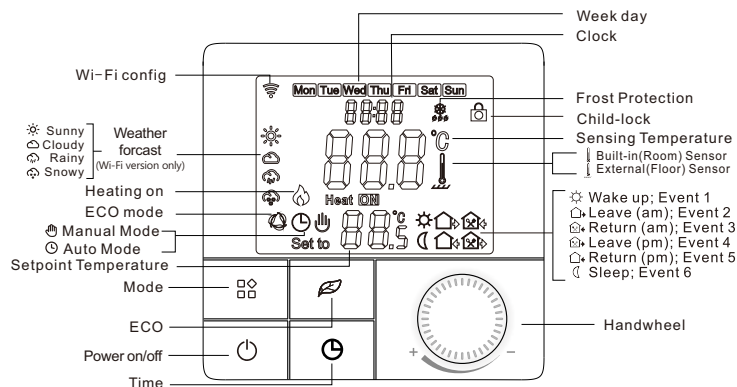

User Operation

Power on/off

Press "⏻" shortly, the thermostat will be turn on/off.

Time setting

Press and hold "🕒" for 3 seconds to enter time setting, and adjust it as follow:
 • Choose modified item by pressing "⏻", and set the week day and clock by rotating handwheel "🕒". Finally, confirm by pressing "⏻" shortly.

Temperature setting

Rotate handwheel "🕒" to increase or decrease setpoint temperature by 0.5°C.

Child-lock

Press and hold "🔒" for 3 seconds to activate child-lock, the thermostat can be locked. Press and hold both keys again to deactivate child-lock.

Temperature Control Mode

Press "🌿" shortly to switch between manual mode and auto mode.
 • Manual Mode: The temperature is controlled in accordance with the current temperature set via handwheel "🕒". It remains activated until the next manual change.
 • Auto Mode: The temperature is controlled in accordance with the set heating profile. Manual changes are activated until the next point at which the profile changes ("🕒" is displayed on the screen). Afterwards, the defined heating profile will be activated again.

ECO mode

Press "🌿" shortly to enter ECO mode, and the temperature will be set to 18°C.

Wi-Fi config (Wi-Fi version only)

Press and hold "🌿" for 3 seconds to enter Wi-Fi config during power off, and add the thermostat on Tuya Smart/Smart Life APP.

Weekly programming setting

For weekdays and weekend up to 6 heating events with individual temperature settings can be saved with the thermostat. Press and hold "⏻" for 3 seconds to enter weekly programming setting, adjust it as follow:

- Choose modified item by pressing "⏻", and set the week day, clock and temperature by rotating handwheel "🕒". Finally, confirm by pressing "⏻" shortly.

Events	Symbols	Time		Temperature		
		Default value	Modify	Default value	Modify	
Weekdays	1	☀️ / ☁️ / ☔️ / ❄️	06:00	🕒 Rotate handwheel	20°C	🕒 Rotate handwheel
	2	🏠 / 🚗 / 🏠	08:00		15°C	
	3	🏠 / 🚗 / 🏠	11:30		15°C	
	4	🏠 / 🚗 / 🏠	12:30		15°C	
	5	🏠 / 🚗 / 🏠	17:00		22°C	
	6	🏠 / 🚗 / 🏠	22:00		15°C	
Weekends	1	☀️ / ☁️ / ☔️ / ❄️	08:00	20°C	🕒 Rotate handwheel	
	2	🏠 / 🚗 / 🏠	22:00	15°C		

Advanced Setting (Usually for Professional Technicians)

During power-off, press and hold "⏻" for 3 seconds to enter advanced setting mode, then re-press "⏻" to switch to next setting item. Finally, confirm by pressing "⏻" shortly.

Code	Meaning	Handwheel "🕒"	Default Value	Floor Heating		
				716	703	723
1ADJ	Temp. calibration	-9.9~9.9°C	0°C	✓	✓	✓
2SEN	Sensor selection	IN: Temp. control based on built-in sensor OUT: Temp. control based on external sensor ALL: Temp. control based on built-in sensor and limited by external sensor	IN	✓	✓	✗
3LIT	External sensor upper limit	5~60°C	35°C	✓	✓	✗
4DIF	Switch deviation	0.5~10°C	1°C	✓	✓	✓
5LTP	Frost protection	ON: frost protection on OFF: frost protection off	OFF	✓	✓	✓
6PRG	Weekly programming setting	12345: 5+2 week mode 123456: 6+1 week mode 1234567: 7+0 week mode	12345	✓	✓	✓
8DLY	Delay time of passive linkage control	0~5min	0	✗	✗	✓
9HIT	Temp. upper limit	5~95°C	50°C	✓	✓	✓
AFAC	Restore factory settings	Press and hold "🌿" for 3 seconds	/	✓	✓	✓

Video support

Scan the corresponding QR code according to your needs to obtain the content.

Operation Video



Mounting Video



Network Video



Dimensions (Unit: mm)

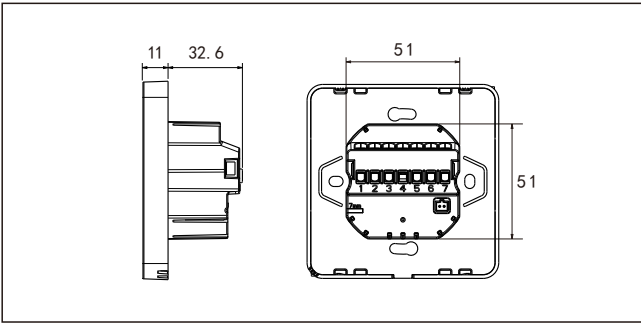

Mounting Steps

The thermostat adopt pre-guide and limited snap-fit design. It is easy to mount.

1) Release front cover by inserting a head screw-driver into bottom crack.

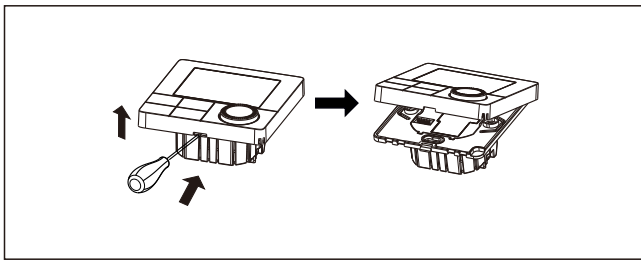

2) Connect wires to terminal block per the wiring schematic according to wiring diagram. (Suggested copper wire length is 7-9mm.)

3) Attach the thermostat base to wall-cassette by two mounting screws After attach it, make sure the there is no deformation on thermostat. (Suggested torque is 0.2~0.4N.m (2.0~4. 1kgf.cm).)

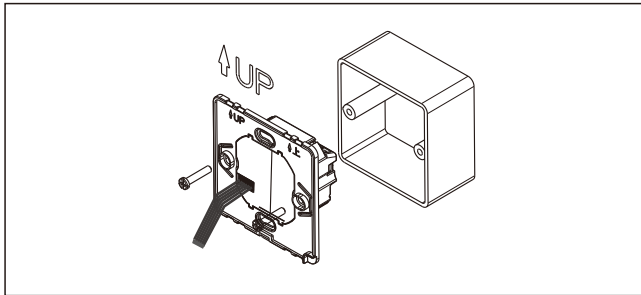

4) Re-mount the front cover via snap-fit connection.

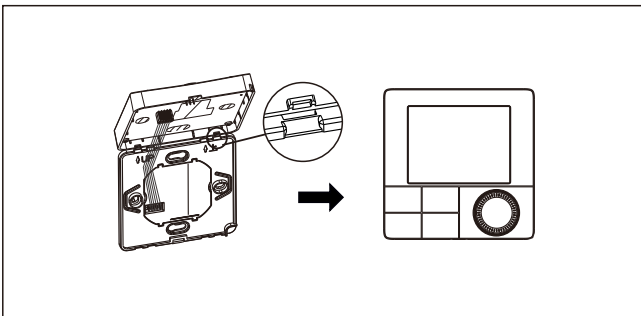

Sensor failure

Please connect the sensor correctly according to your sensor selection setting. When it shows **Er0/Er1** error, thermostat will stay power-off till the error is eliminated.

- **Er0:** Built-in sensor is short-circuited or disconnected.
- **Er1:** External sensor is short-circuited or disconnected.

Wiring Diagram

The thermostat operates in full capacity in areas with the altitude of less than 2500m above sea level. Power rating of external load should be less than or equal to 80% rated power of the thermostat in areas with altitude of 2500m to 4200m.

